

A Case Study on Head Movement Comparative Clauses*

Caterina Donati

Università di Firenze. Dipartimento di Linguistica.
Piazza Brunelleschi, 4. 50121 Firenze. Italy
donatic@dibit.hsr.it

Received: January 31st 1997

Accepted: July 7th 1997

Abstract

According to Chomsky (1995), movement is simply feature movement for checking and the «generalized pied-piping» which shows up in overt syntax is just due to phonological reasons. In this paper I point out that this approach cannot be right, in that the distinction between X and XP movement does exist minimally in syntax, independently from any phonological consideration. Evidence is given that comparative clauses, all other morphological and phonological conditions being equal, minimally contrast with interrogatives in that they involve *head* movement to C° of a Wh-element, instead of *phrase* movement. A brief analysis of the selectional requirements internal to the comparative construction, together with an extension to free relatives, drives to the conclusion that the two types of movement are to be distinguished on the basis of their projecting effects: features moved in head-position do project, and are thus visible from the exterior of the checking domain, while features moved in Spec position do not.

Key words: syntax, movement theory, comparatives, free relatives.

Resum. *Un estudi basat en el cas de les oracions comparatives amb trasllat de nucli*

Segons Chomsky (1995), l'operació de trasllat es redueix al trasllat de trets per a la seva comprovació, i el trasllat amb arrossegament generalitzat que es produeix en la sintaxi explícita es deu simplement a raons fonològiques. En aquest article assenyalo que aquest plantejament no pot ser correcte perquè la distinció entre trasllat de SX i trasllat de X existeix realment en la sintaxi i és independent de qualsevol consideració de tipus fonològic. Es donen proves en el sentit que, donades les mateixes condicions fonològiques i morfològiques, les oracions comparatives contrasten mínimament amb les oracions interrogatives pel fet que impliquen trasllat de *nucli* a C° d'un element QU i no pas trasllat de *projecció màxima*. Una breu anàlisi dels requisits de selecció interns a la construcció comparativa, juntament amb el tractament de les oracions de relatiu sense antecedent, porta a la conclusió que cal distingir els dos tipus de trasllat d'acord amb els efectes de projecció que desencadenen: els trets que es traslladen a una posició de

* Earlier versions of this paper were presented at the Girona Summer School in Linguistics Workshop (July 1996), LSRI, 1997, Irvine (February 1997), and as a «ling lunch» at MIT (February 1997): I thank the audiences for their comments and suggestions. In addition, the paper has benefited a lot from long discussions with Rita Manzini.

nucli es projecten i són, per tant, visibles des de l'exterior del domini de comprovació, però els trets que es traslladen a una posició d'especificador ni es projecten ni són visibles.

Paraules clau: sintaxi, teoria del trasllat, oracions comparatives, oracions de relatiu sense antecedent.

Table of Contents

1. Introduction	6. The Comparative Construction
2. Standard Wh-movement Properties	7. Free Relatives
3. The Anti Pied-Piping Property	8. Conclusion
4. A Head Movement Analysis	References
5. The Status of Head Movement	

1. Introduction

The minimalist theory of movement as recently developed in Chomsky (1995), while being «simple» and maybe right in many respects, has an important limit as it stands now: it is not able to account and not even to predict the existence of two different typologies of (overt) movement in grammar: phrasal movement and head movement. Under Attract theory, movement is simply feature movement for checking and the extra material carried along in overt syntax is just «due to phonological reasons» (Chomsky 1995: 264-265). The case study of comparatives presented here shows however that this approach cannot be right. While displaying all the standard properties typically associated with Wh-movement, comparatives contrast systematically with interrogatives for being associated with Wh-head movement instead of Wh-phrase movement. This minimal contrast cannot be simply reduced to an idiosyncratic property of comparatives since it is reproduced along the same lines in free relatives. In both cases, resorting to a head-movement strategy responds to a precise syntactic requirement which has nothing to do with PF convergence.

The paper is organized as follows: the second and the third sections introduce the basic data the paper deals with, essentially taken from Italian, French and English. The fourth section proposes a new analysis for comparative clauses crucially involving head movement. In order to answer the deep theoretical questions raised in section 5 concerning the status of head-movement, its properties and its trigger, the sixth section is devoted to a brief consideration of the whole comparative construction. Finally, the approach developed for comparatives is extended to free relative clauses, which exhibit similar properties.¹

1. A note of caution is needed here: rather than to provide a full-fledged analysis of the syntax of comparatives, the aim of this paper is to raise a theoretical question about movement and discuss it with arguments taken from comparatives (and free relatives). For a detailed description and analysis of comparative structures, I refer to Donati (1996) and Donati (forthcoming).

2. Standard Wh-movement Properties

By comparative clauses, I mean the II term of comparison when it takes a clausal form. To be concrete, the parenthesized bits in (1) are instances of comparative clauses in English, French and Italian.

- (1) a. Mary eats more cookies [than Paul eats].
 b. Marie mange plus de biscuits [que n'en mange Paul].
 Mary eats more of cookies than neg.of-them eats Paul
 'Mary eats more cookies than Paul does.'
 c. Maria mangia più biscotti [di quanti ne mangia Paolo].
 Mary eats more cookies than WH-pl of-them eats Paul
 'Mary eats more cookies than Paul does.'

As is well known since Bresnan (1973, 1975) and Chomsky (1977), comparative clauses exhibit all the typical properties associated with Wh-movement structures. (2) and (3), for example, illustrate their sensitivity to island effects: (2) are violations of the so-called Complex NP Constraint; (3) are Wh-islands violations.

- (2) a. *I ate more cookies than I met a man who ate [e].
 b. *J'ai mangé plus de biscuits que je n'ai rencontré un homme
 I.have eaten more of cookies than I neg.have met a man
 qui en a mangés [e].
 who of-them has eaten
 c. *Ho mangiato più biscotti di quanti ho incontrato un uomo
 I-have eaten more cookies than WH-pl I-have met a man
 che ne ha mangiati [e].
 who of-them has eaten
- (3) a. *I ate more cookies than I wonder who ate [e].
 b. *J'ai mangé plus de biscuits que je me demande qui en
 I.have eaten more of cookies than I wonder who of-them
 a mangés [e].
 has eaten
 c. *Ho mangiato più biscotti di quanti mi chiedo chi ne
 I-have eaten more cookies than WH-pl I-wonder who of-them
 abbia mangiati [e].
 has eaten

Italian is of course particularly transparent in this respect, since it involves overt movement of the Wh-element *quanto* (see 1c, 2c, 3c). *Quanto* is also used in interrogatives, exclamatives and in free relatives. The same overt movement is observable in some varieties of American English, where comparatives may involve the Wh-element *what*:

- (4) John is taller than what Mary is [e]. (Chomsky 1977: 87)

3. The Anti Pied-Piping Property

In addition to these typical Wh-movement properties, comparatives display however one peculiar and weird property which strongly distinguishes them from other standard movement structures, such as questions or (full) relative clauses: they display a strict anti pied-piping property, illustrated in English by the contrast between (5) and (6).²

- (5) a. [How many cookies] did you eat [e]?
 b. [To how many persons] did you talk [e]?
- (6) a. *Mary ate more cookies than [[e] candies] she ate [e].
 b. *I talked to more people than [to [e]] I wrote [e].

In comparatives, the null operator can neither pied-pipe its nominal complement (as in (6a)), nor a preposition governing it. (5) shows that the same two options are perfectly admissible in interrogative clauses. For English (and for French, where this restriction holds too) this could be a false problem: both languages involve abstract movement in comparatives, and we have good reasons to assume that covert movement is incompatible by definition with pied-piping, independently from the comparative structure. In the GB framework, this anti pied-piping property has been traditionally derived from the licensing conditions of the null operator assumed to be involved (see Browning 1987). Under a Minimalist perspective, covert operations, being free from any phonological requirement, are reduced to pure instances of Move-F.

The same anti pied-piping property holds however overtly in Italian: the wh-element *quanto* must remain strictly bare when introducing a comparative, such as the two sentences in (7).

- (7) a. *Ho mangiato più biscotti di [quante caramelle] abbia
 I-have eaten more cookies than how-many candies I-have
 mangiato [e].
 eaten
 'I ate more cookies than I ate candies.'
- b. *Ho parlato a più persone di [a quante] abbia scritto [e].
 I-have talked to more people than to how-many I-have written
 'I talked to more people than I wrote to.'

This restriction cannot be reduced to an idiosyncrasy of *quanto*, since the very same Wh-element is freely allowed to pied-pipe whatever constituent when introducing an interrogative or any other standard movement construction, as shown in (8):

2. Bresnan (1975) already noticed this phenomenon as a problem for a Wh-movement interpretation of her analysis of comparative clauses in English: cf. pp. 63-64.

- (8) a. [Quanti biscotti] hai mangiato [e]?
 how-many cookies have-you eaten
 'How many cookies did you eat?'
 b. [A quante persone] hai parlato [e]?
 to how-many people have-you talked
 'How many people did you talk to?'

This anti pied-piping property can neither be linked to some interpretive restriction due to the comparison operation. In Italian, it is always possible to paraphrase a comparative by means of a relative clause, and in this case the restriction fails to apply to the resulting comparison:

- (9) a. Maria ha mangiato più biscotti delle caramelle che ha mangiato
 Mary has eaten more cookies than the candies that has eaten
 Giulia.
 Julia
 'Mary ate more cookies than Julia ate candies.'
 b. Ho parlato a più persone di quelle a cui ho scritto.
 I-have talked to more people than those to whom I-have written
 'I talked to more people than I wrote to.'

Finally, there is some crosslinguistic evidence for the generality of this anti pied-piping property of the movement involved in comparatives. Romanian, for example, which involves as well overt movement in comparatives, displays the same contrast with respect to interrogatives, as illustrated in (10).³

- (10) a. [Cît de frumoasa] e Maria [e]?
 how-much of beautiful is Mary
 b. *Maria e cu mult mai desteapta [decît de frumoasa] e
 Mary is with much more clever than-how-much of beautiful is
 Zamfira [e].
 Zamfira

4. A Head Movement Analysis

At a superficial level, this minimal contrast between comparatives on one hand and interrogatives and other standard Wh-movement structures on the other hand looks very much like a contrast between head movement and phrasal movement. And indeed the most simple way of accounting for it should hold precisely in these terms: interrogatives involve phrasal movement, therefore allowing and compelling

3. These data are taken from Grosu (1994: 207). Notice that his interpretation of the facts in (10) is rather different from mine, since he interprets comparatives as not involving movement on the very basis of the anti pied-piping property they display.

a certain amount of pied-piping. Comparatives involve bare head movement, therefore no pied-piping. The derivation I assume for Italian comparatives is illustrated in (11):

- (11) a. Paolo ha mangiato più biscotti di quanti ne ha mangiati Maria.
 b. Paolo ha mangiato più biscotti ...

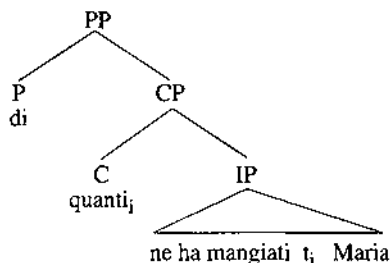

In other words, I claim that the defining property of comparatives is that they involve the movement of a quantifier head directly to C°. This explains both the typical Wh-movement properties illustrated in section 1, and the weird anti pied-piping condition discussed in section 2.

I will assume that the same derivation holds for comparatives in English and French, although they involve no overt Wh-element and this Q-movement is therefore abstract.

An interesting consequence of the analysis introduced in (11) is that it predicts another important asymmetry that appears to hold between comparatives and interrogatives with respect to movement.⁴ The relevant facts are given in (12).

- (12) a. Mary ate more cookies than she ate [[e] candies].
 b. *How many did Mary eat [[e] candies]?

(12) shows that comparatives allow a type of movement which is strictly forbidden in interrogatives: but this is directly predicted by the head movement analysis, as a perfect counterpart of the anti pied-piping property discussed above. Since comparatives involve head movement, the Q-head of a quantified NP may raise stranding its nominal complement: (12a). The same operation in interrogatives violates the phrase structure rule which bars a head from sitting in a specifier position: (12b).

The minimal contrast displayed in English illustrated in (12), which is to be seen as a clear corollary of the head-movement analysis, is frequently obscured in other languages, like Italian and French, by the interference of other factors akin to the

4. Bresnan (1975) had noticed this further peculiarity of comparatives as a problem for a movement analysis of the clause: cf. p. 59-60.

syntax of quantification in general (Giusti 1992, Zamparelli 1993).⁵ However, independent evidence that the contrast in (12) is really due to a deep syntactic difference between comparatives and interrogatives is provided by Bulgarian, which displays *overtly* the same contrast observable *covertly* in English:⁶

- (13) a. Ivan izpi povece vino ot-kolkoto Maria izpi [[e] bira].
 Ivan drinks more wine than.how much Mary drinks beer
 'Ivan drinks more wine than Mary drinks beer.'
- b. *Kolko izpi Maria [[e] bira]?
 How-much drinks Mary beer
 'How much does Mary drink beer?'

5. The Status of Head Movement

The structure in (11), while correctly predicting the empirical facts presented above, raises however two deep theoretical questions concerning the status of head movement, reported in (14):

- (14) a. What allows head movement?
 b. What bars phrasal movement?

The answer to the first is straightforward under current minimalist assumptions: head movement is allowed because nothing blocks it. Under Attract Theory, what really moves are features, and heads are the minimal «bundles of features» visible by overt syntax. As for locality requirements, the long Q-movement involved in (11) satisfies the Minimal Link Condition as defined in Chomsky (1995).

(15) *Minimal Link Condition*

K attracts α only if there is no β , β closer to K than α , such that K attracts β .
 (Chomsky 1995: 311)

5. In Italian in particular, the movement of the quantifier stranding its nominal complement is never allowed, neither in interrogatives (as expected), nor in comparatives:

- (i) a. *Quante ha mangiato [[e] caramelle] Maria?
 how-many has eaten candies Mary
 b. *Paolo ha mangiato più biscotti di quante Maria ha mangiato [[e] caramelle].
 Paul has eaten more cookies than how-many Mary has eaten candies.

In French, the opposite situation holds: the quantifier (which projects a partitive structure) can strand the nominal phrase both in comparatives (as expected) and in interrogatives.

- (ii) a. Combien a-t-il mangé [[e] de biscuits]?
 How-many has.he eaten of cookies
 b. Marie a mangé plus de bonbons que Paul a mangé [[e] de biscuits].
 Mary has eaten more of candies than Paul has eaten of cookies.

See Donati (1996) and Donati (forthcoming) for a detailed account of these facts in the two languages.

6. The Bulgarian data are taken from Izvorski (1995).

The legitimacy of (15), and its impact on the theory of locality in general would deserve much discussion. For what concerns us here, however, it amounts to say that there exists no such thing as the Head Movement Constraint.⁷ Or, to put it differently, (15) claims simply that locality is not sensitive to the *amount* of material subject to movement, but rather to its *nature*, defined in terms of features. As far as a Wh-feature is involved, therefore, there will be no difference in locality whether it moves as a head or as a phrase. Concretely in (11), according to (15), the quantifier feature embedded in *quanto* is the closest feature that can be attracted by the head C°.

The second question is more difficult to answer: what bars pied-piping of the whole phrase in (11)? In other words, what forces the grammar in comparatives (but not, say, in interrogatives) to check the features embedded in C° in a head-head configuration, rather than in a specifier-head configuration? Notice that this corresponds in fact to a more general question, which should be raised independently from the syntax of comparison we are investigating. The checking theory adopted by minimalism has inherited from the generative tradition a fundamental, unexplained duplicity which cries for an explanation. In any checking domain, there are systematically two checking configurations available: a head-head configuration, and a spec-head configuration. What is missing in the theory is an explicit account of what drives the choice between the two options.

In order to answer this question at least for the comparative case, it may be useful to have a look a little higher up in the syntactic tree, and see how the comparative clause fits in the whole comparative construction.

6. The Comparative Construction

Consider again a simple comparative construction as (11a), repeated here as (16).

- (16) Paolo ha mangiato più biscotti di quanti ne ha mangiati
 Paul has eaten more cookies than WH-pl of-them has eaten
 Maria [e].
 Mary
 'Paul ate more cookies than Mary did.'

The simplest intuition about this construction is that it compares two quantities of cookies: the quantity of cookies eaten by Paul, and the one eaten by Mary. One way of expressing this naive intuition is given in (17), a rough structural representation for (16).

7. The claim that there exists no HMC and that long head movements as the one discussed here are legitimate had already been made by several scholars in a pre-minimalist framework. Cf. in particular Rivero (1991), Roberts (1994), Manzini (1994).

(17)

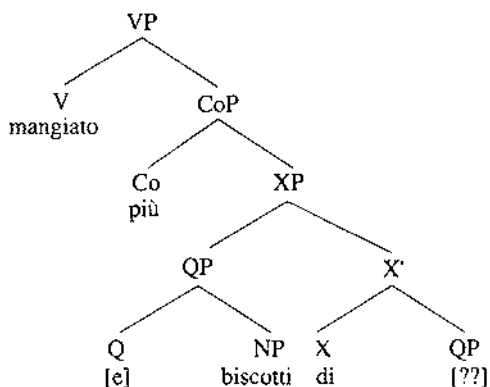

The basic idea of the analysis sketched in (17) is that the entire comparative construction is selected by *più/more*, a two-place predicate taking the two terms of comparison as its arguments.⁸ The preposition *di* is inserted in the structure as a dummy conjunction-like element, whose only purpose is to establish the antisymmetric order required by syntax⁹ between the two arguments of *più*. But what is most crucial for our concerns here is that these two arguments are two quantified phrases.

The quantifier inserted as the head of the first term of comparison (the «external argument» of *più*) is clearly abstract in (16), as is generally the case in standard Italian. Many spoken varieties, however, overtly realize it, yielding sentences like (18).

- (18) a. Maria ha mangiato più tanti biscotti di quanti ne ha
 Mary has eaten more many cookies than how-many of-them has
 mangiati [e] Joe.
 eaten Joe
 'Mary ate more cookies than Joe did.'
- b. Maria ha mangiato più pochi biscotti di quanti ne ha
 Mary has eaten more few cookies than how-many of-them has
 mangiati [e] Joe.
 eaten Joe
 'Mary ate fewer cookies than Joe did.'

8. For sake of simplicity, the diagram in (17) abstracts from the derivational history of the structure, which is irrelevant for the present discussion. At base-structure, there is evidence for the generation of the comparator *più* in the position of X° , where it forms a constituent with the most embedded QP, to which the higher QP attaches as an external argument. For a detailed discussion of the construction, and of the trigger of the raising of *più* to its final position, see Donati (1996) and Donati (forthcoming). See also Izvorski (1995) for a similar approach, which explicitly identifies the comparative construction with a sort of a Larsonian shell.

9. Assuming Kayne (1994)'s *Linear Correspondence Axiom* or the version of it subsumed by Chomsky (1995) under his bare phrase structure model.

Now the next question is: what about the second QP, the «internal argument» of *più*? How can a bare CP like (11) be inserted in such a structure? How can it satisfy the selection requirement of the *più*-predicate, which imposes a quantifier phrase as its internal argument? Here comes into play the head movement of *quanti* we are trying to explain. It is by virtue of this Q-movement that a bare CP in the complement position of *di* doesn't violate these selectional restrictions. Raising as a head into the C° position, *quanti* endows this head with the quantifier features required by the external selector *più*. Putting it another way, the head movement of *quanti* is required in order to make a proper QP out of the bare comparative CP. The complete representation of (17) will then be as in (19):

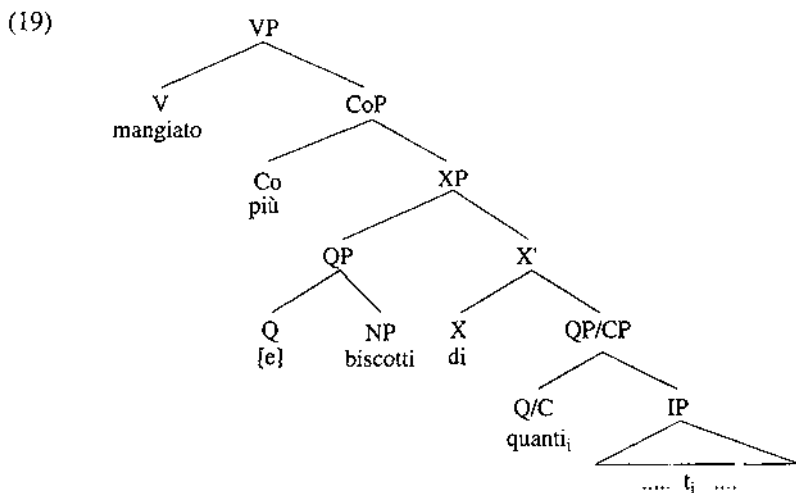

The contrast between comparatives on the one hand and interrogatives on the other hand, namely head movement versus phrasal movement, now becomes clear: comparatives involve head movement because they need to externalize the quantifier feature embedded in the Wh-quantifier; interrogatives involve phrasal movement because on the contrary they need not to externalize the very same feature. The result is that interrogatives are pure sentences, while comparatives are in fact complex nominal sentences.

This nominal status of comparatives is indirectly confirmed by another strong asymmetry that distinguishes comparatives from interrogatives: while the latter are weak islands (i.e. they selectively block adjunct movement, while allowing argument extraction), the former are strong islands. This contrast is exemplified in (20) vs. (21):

- (20) a. *How did Mary ask whether Paul has fixed many cars [e]?
 b. What did Mary asked whether many people eat [e]?
- (21) a. *How did Mary fix more cars by herself than Paul has fixed [e]?
 b. *What did more people eat cookies than ate [e]?

7. Free Relatives

Before concluding, it is interesting to observe that this approach successfully extends to free relatives. The idea that comparatives and free relatives should be analysed as very close structures is not new in the literature,¹⁰ but the analysis proposed here can help understand more clearly this traditional intuition.

Notice first of all that the same weird restriction on movement described above for comparatives (see section 3) appears to hold independently, and exactly along the same lines, in free relatives. This is shown in (22) and (23), respectively for English and Italian.

- (22) a. *John considers [about what] Mary is talking [e].
 b. *I will visit [what town] you will visit [e].
- (23) a. *Mario ascolta [di quanto] sta parlando [e] Maria.
 Mario listens of what is talking Mary
 b. *Mario ha già incontrato [quanti uomini] stanno parlando [e] con
 Mario has already met what men are talking to
 Maria.
 Mary

In (22a), the *wh*-element pied-pipes a preposition governing it, and the sentence is out; in (22b), it pied-pipes its nominal complement, and the result is again ungrammatical. The same is true in Italian: (23a) is a case of «upward» pied-piping of a preposition; (23b) is a case of «downward» pied-piping of a nominal: both are unacceptable.

The most natural step is to interpret this anti pied-piping property along the same lines as we did for comparatives: as a symptom of head movement. The analysis I would like to propose for free relatives is given in (24).

- (24) a. What you will eat [e]
- b.
-
- ```

graph TD
 CP --> C["C
whati"]
 CP --> IP["IP
... you will eat ti ..."]

```

The basic idea is that free relatives simply lack a syntactic layer, namely the external determiner typically associated with full relative clauses which gives a DP

10. Cf. Bracco (1980), Larson (1987), Grosu (1994), Izvorski (1995), Donati (1996) among others. See also den Besten (1978) and Hazout (1995) for two independent rejections of this identification.

status to them.<sup>11</sup> But a bare CP inserted in an argument position like (24) would violate the selection of the verb:

(25) I will eat [<sub>CP</sub> what you will eat [e]].

Therefore free relatives involve the same strategy we have seen at work in comparative clauses: head movement. The raising of a determiner-like head to the C° position provides the CP with the required nominal features, and eventually makes a DP out of a CP.<sup>12</sup>

(26) I will eat [<sub>DP/CP</sub> what you will eat [e]].

## 8. Conclusion

The case study of comparative and free relative clauses briefly presented here may help providing a first answer to a deep theoretical question raised under the minimalist approach: is there any principled distinction between head movement and phrase movement? Against what suggested in Chomsky (1995), this article shows that the typology of overt movement has nothing to do with PF properties.

Rather, head movement and phrase movement have different syntactic properties. Given the same checking domain, both X-movement and XP-movement can do the job, but only the former has the property of making the features carried along visible from outside the checking domain.

11. Under the analysis proposed by Kayne (1994) and Bianchi (1995). See Donati (1996) for a more detailed discussion of free relatives along these lines.

12. There is a well known class of free relatives —or, better, “apparent” free relatives— which clearly escape this generalization, both in English and in Italian, i.e. the ones involving the suffix *-ever* (*-unque* in Italian): as shown in (11), this class of clauses freely allow “downward pied piping” of a nominal or any other complement of the Wh-operator, still prohibiting “upward pied-piping” of a preposition.

(i) a. I will visit [whatever town] you will visit.

b. Visiterò [qualunque città] vorrai visitare.

(ii) a. \*John considers [about whatever question] Mary is talking.

b. \*John considera [di qualunque questione] stia parlando Maria.

Following an idea suggested by Kayne (1994:154 fn), I will assume that the structure underlying these clauses is that of a full relative, with *-ever* selecting the CP:

(iii) I will visit [<sub>DP</sub> ever [<sub>CP</sub> [what town]<sub>i</sub> [<sub>C</sub> ..... t<sub>i</sub> ..... ]]]

For some reason due to its universal value, *-ever* forces the raising of the Wh-determiner, giving (iv):

(iv) ... [<sub>DP</sub> [<sub>D</sub> what<sub>j</sub> [<sub>D</sub> ever]] [<sub>CP</sub> [t<sub>i</sub> man]<sub>i</sub> [<sub>C</sub> ..... t<sub>i</sub> ..... ]]]

where the head *what* left-adjoins to *ever*. Under this analysis, the ungrammatical examples in (ii) would imply the adjunction of a PP to a head, an impossible move for principled reasons.

## References

- Besten, H. den (1978). «On the Presence vs. Absence of Wh-elements in Dutch Comparatives». *Linguistic Inquiry*, 9: 641-671.
- Bianchi, V. (1995). *Consequences of Antisymmetry for the Syntax of Headed Relative Clauses*. Scuola Normale Superiore Pisa. PhD dissertation.
- Bracco, C. (1980). «On the Island Character of Italian "quanto" Comparatives». *Journal of Italian Linguistics*, 5: 19-46.
- Bresnan, J. (1973). «Syntax of the Comparative Construction in English». *Linguistic Inquiry*, 4: 275-343.
- Chomsky, N. (1977). «On wh-movement». In Culicover, P.; Wasow, T.; Akmajan, A. (eds.). (1977), p. 91-132.
- (1995). *The Minimalist Program*. Cambridge, Mass: MIT Press.
- Culicover, P.; Wasow, T.; Akmajan, A. (eds.). (1977). *Formal Syntax*. New York: Academic Press.
- Donati, C. (1996). «Comparatives as Free Relatives: a Raising Analysis». To appear in *Probus*.
- (forthcoming). *La sintassi della comparazione*. Università di Firenze. PhD dissertation.
- Giusti, G. (1992). *La Sintassi dei sintagmi nominali quantificati*. Università di Venezia. PhD dissertation.
- Grosu, A. (1994). «The Syntax of Free Relative Constructions». In *Three Studies in Locality and Case*. London: Routledge.
- Hazout, I. (1995). «Comparative Ellipsis and Logical Form». *Natural Language and Linguistic Theory*, 13: 1-37.
- Hornstein, N.; Lightfoot, D. (eds.). (1994). *Verb Movement*. Cambridge: Cambridge University Press.
- Izvorski, R. (1995). «A DP-Shell for Comparatives». *Console III Proceedings*. The Hague: Holland Academic Graphics, p. 99-121.
- Kayne, R. (1994). *The Antisymmetry of Syntax*, Cambridge, Mass: MIT Press.
- Larson, R. (1987). «Missing Prepositions and the Analysis of English Free Relative Clauses». *Linguistic Inquiry*, 18: 239-266.
- Manzini, M.R. (1992). *Locality: a Theory and some of its Empirical Consequences*. Cambridge, Mass: MIT Press.
- Roberts, I. (1994). «Two Types of Head Movement in Romance». In: N. Hornstein; D. Lightfoot (eds.). (1994), p. 207-242.
- Zamparelli, R. (1992). «On the Spec vs. Head Status of Quantifiers and Adjectives». *GLOW Newsletter*, 30.